

High Resolution

# Digital Controllers

**CO series**



GPIB

USB

RS-485

RS-232C

digital controller  
digital controller

digital controller  
digital controller

# Digital Controller

The CO Series is a line of adapters used to digitally control Matsusada's High Voltage, DC, and AC power supplies via personal computer. In addition to enabling manufacturing line automation and speeding up R&D, the CO series is ideally suited to building safe, stable, versatile and highly accurate automatic inspection and measurement systems, saving you time and cutting labor costs.

The CO Series utilizes fiber optic cables for the digital communication, assuring highly communication in even the noisiest environments, including the factory floor. The fiber optic connection also secures electrical isolation, resulting in safer operation even when combined with power supplies of different potentials.

The CO Series boasts a multitude of functions, including high resolution 16 bit(1/65535) control and read back or status output. This promises the CO Series is ideal for Research & Development, quality control, production lines that require high accuracy. The CO Series is also ultra-compact, allowing you to place them practically anywhere, saving valuable shelf and floor space.



## For the Features Section

- ▶ **Interface:** GPIB, RS-232C, RS-485, or USB
- ▶ **Resolution:** 16 bit(1/65535)
- ▶ **Isolation:** Fiber optic cable(optical link only)
- ▶ **Functions:** PC Control, Listener/Talker, Read Back or Status
- ▶ **Size:** 1.5"W × 4.9"H × 5.9"D
- ▶ **Enable to directly control from sequencer(PLC)\***

\* Require a RS-232 port for communication

## Functions

Combination of adapters	Power Supply		RE, RF series			RG series	AU,AE,AF,ES, W,K7-R series
	Adapters 1			CO-U32	LUs1(Option of RE,RF)	CO-U32	CO-U32
Functions	with USB						
	with RS-232C RS-485			Optical RS-232C module Optical RS-485 module		Optical RS-232C module Optical RS-485 module	Optical RS-232C module Optical RS-485 module
	with GPIB	LGb (Option of RE)		CO-G32		CO-G32	CO-G32
	Adapters 2 (Combine with Adapters 1)			LGOB (Option of RE,RF)		CO-RG	CO-HV
Output Voltage control and setting checking				16 bit or 100.00%		16 bit or 100.00%	16 bit or 100.00%
Output Current control and setting checking				16 bit or 100.00%		16 bit or 100.00%	16 bit or 100.00% *2
Output voltage monitor				12 bit or 100.00%		12 bit or 100.00%	12 bit or 100.00%
Output current monitor				12 bit or 100.00%		12 bit or 100.00%	12 bit or 100.00%
Remote ON/OFF				O		O	O
CVP control				12 bit or 100.00%		-	-
CV mode status				O		-	-
CC mode status				O		-	-
OVP status				O		-	-
OTP status				O		-	-
ACF status				O		-	-
UV status *3				O (UV setting : 16 bit or 100.00%)		-	-
UC status *4				O (UC setting : 16 bit or 100.00%)		-	-
Output status				Stop by ON or FLT		OUTPUT switch position	ON or OFF
Output reset				O	*5	-	O *6
Polarity change				-		-	O *7

Combination of adapters	Power Supply		RK-80 series		RK-400, RK-800, RK-1200, REk series		
	Adapters 1			LUs1 (Option of RK-80)		LUs1 (Option of RK-400, RK-800, RK-1200, PRk)	CO-U32
Functions	with USB						
	with RS-232C RS-485		Metal RS-232C module Metal RS-485 module		Metal RS-232C module Metal RS-485 module		Optical RS-232C module Optical RS-485 module
	with GPIB		CO-G32m		CO-G32m		CO-G32
	Adapters 2 (Combine with Adapters 1)		LGmb (Option of RK-80)		Standard *8		LGOb (Option of RK-400, RK-800, RK-1200, PRk) *8
Output Voltage control and setting checking			8 bit or 100.0% or voltage value *9			16 bit or 100.00% or voltage value	
Output Current control and setting checking			8 bit or 100.0% or current value *9			16 bit or 100.00% or current value	
Output voltage monitor			10 bit or 100.0% *10			12 bit or 100.00% or voltage value	
Output current monitor			10 bit or 100.0% *10			12 bit or 100.00% or current value	
CVP control			8 bit or 100.0% or voltage value *9			8 bit or 100.0% or voltage value	
OCP control			-			8 bit or 100.0% or current value	
Remote ON/OFF			O			O	
Output range change			O			-	
CV mode status			O			O	
CC mode status			O			O	
OVP status			O			O	
OCP status			-			O	
OTP status			O			O	
ACF status			O			O	
RS status			-			O	
LD status			-			O	
Output status			O			O	
Output reset			O	*11		O	*12

\*1)AF, AE, ES series need LG option to connect to CO series adapters. \*2)Except for AF, AE, ES, K7-R, series. For AU this become overload, trip control and setting checking. \*3)Indicate the status of voltage drop due to short circuit, etc. \*4)Indicate the status of current drop due to output wire cutting, etc. \*5)Reset the output cut off mode due to OVP. \*6)Except for AU, W, ES and AF, AE with LC option. \*7)Only for K7-R series. \*8)-LUs1 and -LGOb option shall eliminate standard digital interface. \*9)Setting resolution of output voltage(current) is 1/256 of rated voltage(current) of maximum voltage(current) range. \*10)Monitor resolution of output voltage(current) is 1/1024 of rated voltage(current) of maximum voltage(current) range. \*11)Reset the output cut off status by OVP, OTP and RS function. \*12)Reset the output cut off status by OVP, OCP, OTP, RS and LD function.

### SPECIFICATIONS

#### CO series

**Input Voltage:** 100 to 240VAC 50/60Hz 1Ø

**Isolation Voltage:** AC1.5kV for 1 min between primary-secondary

\*Except for Optical RS-232C module/Optical RS-485 module

**AC input cable:** 1.8m

**COS series Input Voltage:** +24VDC

\*Input terminal: lead wire 1m with solder plated terminal

**COT series Input Voltage:** +5VDC

\*Input terminal: lead wire 1m with solder plated terminal

### DIMENSIONS inch(mm)

#### CO-G32, CO-U32, CO-G32m, CO-RG, CO-HV

1.50(38)W × 4.88(124)H × 5.91(150)D  
(Can be placed horizontally)

#### Optical RS-232C module

2.13(54)W × 0.67(17)H × 2.17(55)D

#### Optical RS-485 module

2.13(54)W × 0.63(16)H × 2.09(53)D

### OPTIONS

**-LH** : High voltage isolation only for CO-RG  
\*Needed when combined with RG of over 120V output.

**-LFC1** : When CO-Opt cable of 15m to 30m is required  
\*Except for LGb, LUs1 or RK series

**-LFC2** : When CO-Opt cable of 30m to 40m is required  
\*Except for LGb, LUs1 or RK series

When ordering, please suffix the above option number to the model number.  
<e.g.>CO-RG-LFC1H alphabetical order

## Accessory

<b>CO-G32</b> <b>CO-U32</b>	Instruction Manual (1), Rubber feet (4)	<b>CO-HV</b>	Opt cable(Case(A)) CO-opt cable (1)	
<b>LGob</b>	Opt cable(Case(A)) CO-opt cable (1)		Control cable(Case(C)) Either CO-AU cable, CO-AF cable, CO-W cable or CO-K7 cable	
<b>CO-RG</b>	Opt cable(Case(A)) CO-opt cable (1)		)	- CO-AU cable is required when combined with AU series - CO-W cable is required when combined with W series - CO-K7 cable is required when combined with K7-R series - CO-AF cable is required when combined with AE,AF or ES series - When purchased together with HV power supply, a mating cable come together with power supply. - When order only CO-HV or cable, specify the cable part number <e.g.> CO-HV(with CO-AU cable), CO-AF cable
	Control cable(Case(B)) Standard: CO-RG cable (1) Option -LH: CO-RGH cable (1) (Option -LH is required for CO-RG unit when combined with RG series of over 120V voltage. When ordering cable alone, specify CO-RG cable or CO-RGH cable.)			
	<b>LGmb</b>			Modular cable(Case(D)) CO-M cable (1)

Length of all the cable is 2m. For CO-opt cable only, specific length can be ordered from 0.2m to maximum 15m. Please contact to sales offices for extended cable. When ordering please suffix length in ( ) to the part number CO-opt cable

<e.g.> CO-RG (CO-opt cable (5))  
CO-opt cable (3)

## Interface Specifications

### Digital specification

- GPIB**
- Electrical specification** IEEE488-1978 conformable
- Mechanical specification** IEEE488-1978 conformable
- Interface function** SH1, AH1, L4, T6, SR1, RL0, PP0, DC1, DT0, CO
- Address setting** Desired address can be assigned from 0 to 30 with address switch.
- Delimiter** Combination of E01 and LF
- Service Request Function** Indication of output status and shut off status of controlled power supply

### RS-232C/RS-485

- Speed** Asynchronous 9600bps(fixed)
- Data Length** 8bit
- Parity** None
- Stop Bit** 1bit
- Flow control** None

- Cable which connect ports of Opt RS-232C module and Opt RS-485 module is to be prepared by customer.

- Connector for input is Dsub-25pin(male) type.

(RS-232C: Data input PinNo.2 Data output PinNo.3 GND PinNo.7)

(RS-485: Data input + PinNo.16 Data output - PinNo.19  
Data input + PinNo.13 Data output - PinNo.14 GND PinNo.7)

### USB

USB 1.1 conformable Windows driver is assorted

### Analog Specification

- Control section**
- Setting accuracy** +0.1%
- Temp. Coeff.** 100ppm/°C
- Monitor section**
- Reading accuracy** ±0.2%±2digit
- Temp. Coeff.** 200ppm/°C

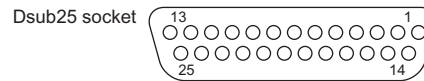

Pin No.	Function	command
1	Output voltage setting (0V to 10V)	CH0,VCN
2	Output current setting (0V to 10V)	CH1,ICN
18	Over voltage protection setting (0V to 10V)	CH2,OVP
15	Voltage monitor (0V to 10V)	MN1,VM
3	Current monitor (0V to 10V)	MN2,IM
4, 21	Output ON/OFF signal	SW
8	Cut off reset signal	RST
20	Remote/Local setting	REN/GLT
16	SRQ	SRQ
11	Fault status	SRQ
12	CV mode status	STS
13	CC mode status	STS
5, 6, 10	COMMON	-

## Dimensions inch(mm)

### CO-G32 / CO-U32 / CO-G32m / CO-RG / CO-HV

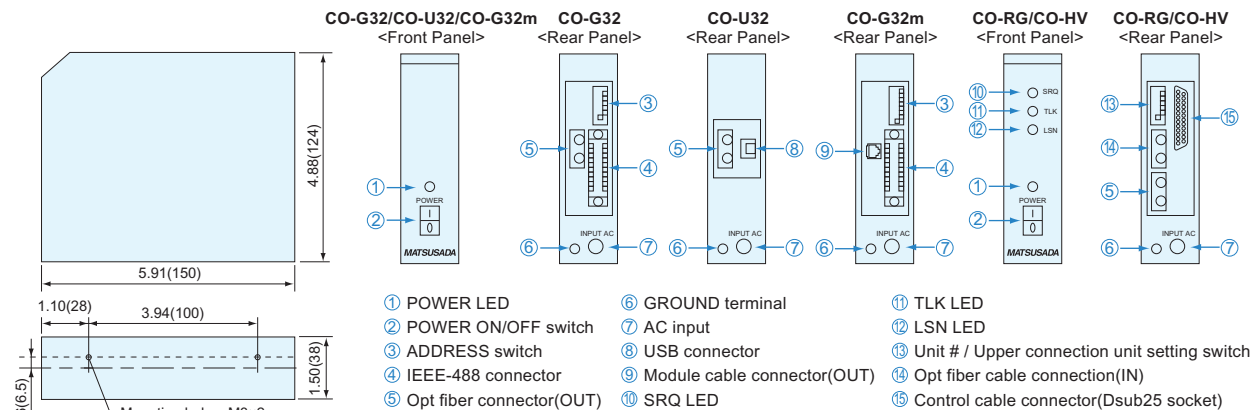

### Optical RS-232C module / Optical RS-485 module

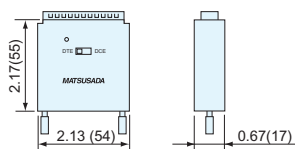

## Connection

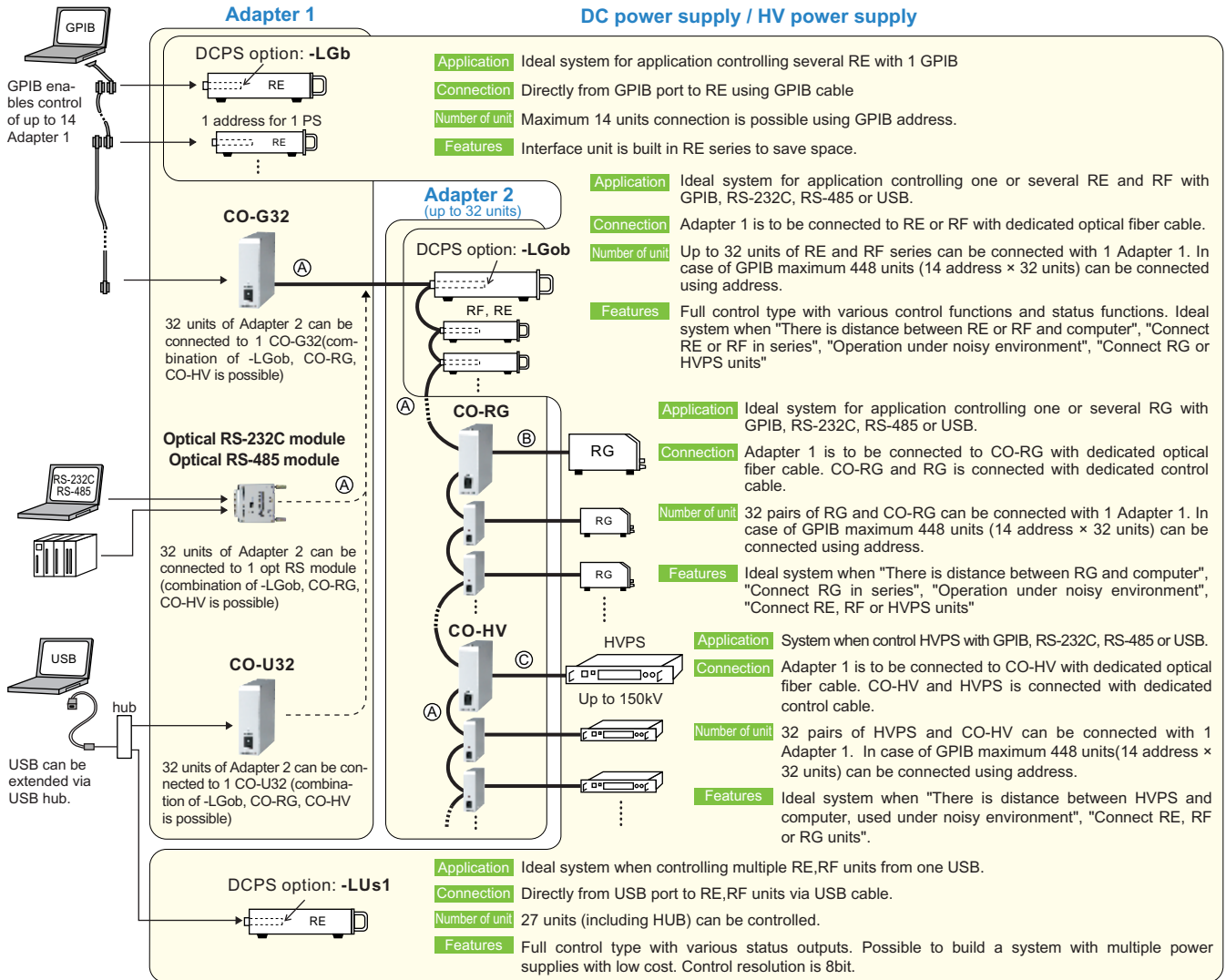





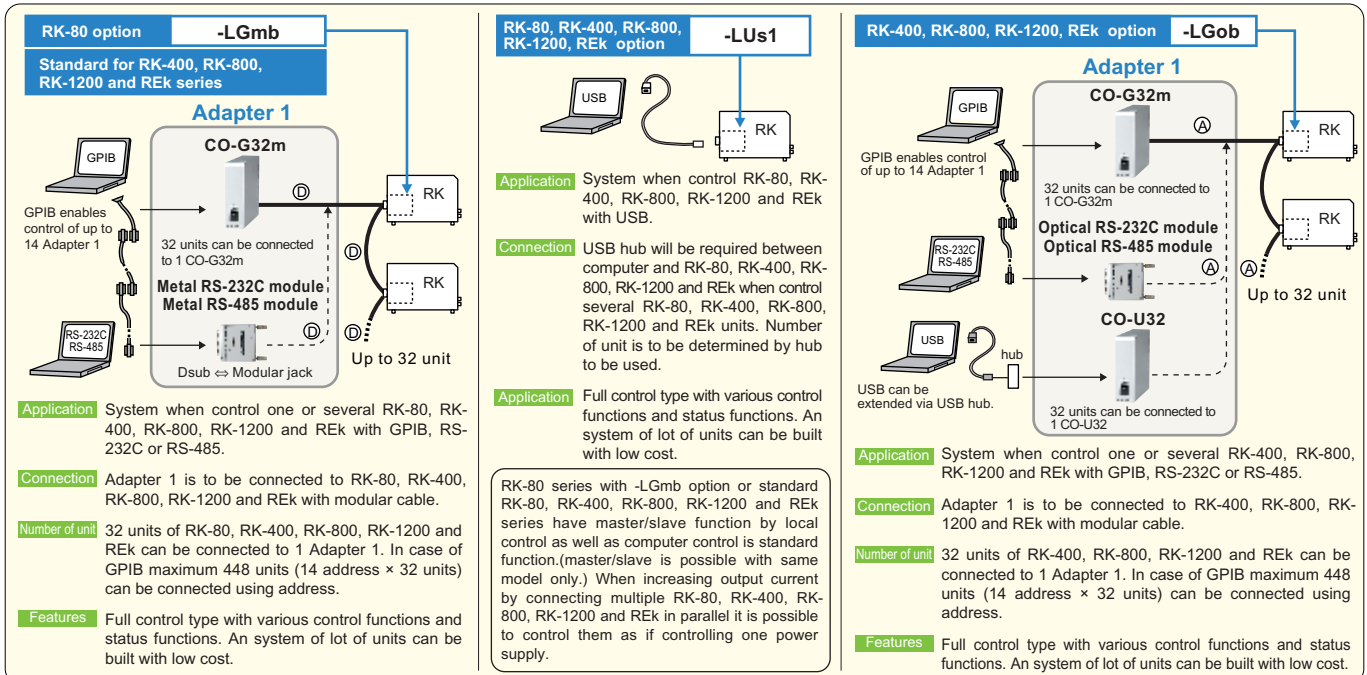

## RK REK SERIES CONNECTION EXAMPLE

\*See Accessory on page 4 for cable (A)-(D).



# Introduction of Matsusada high voltage power supplies

<p><b>RE series</b></p> <p><b>High power DC power supply</b></p>  <ul style="list-style-type: none"> <li>▪ 10V to 650V 15kW</li> <li>▪ Compact and light weight</li> <li>▪ Full of remote functions</li> </ul>	<p><b>AU series</b></p> <p><b>Rack-mountable high voltage power supply</b></p>  <ul style="list-style-type: none"> <li>▪ Constant-voltage / Constant-current control</li> <li>▪ Low profile and light weight</li> <li>▪ Quick delivery</li> <li>▪ 1kV to 120kV, Total 315 models ranging from 30W to 1.2KW</li> </ul>
<p><b>RK series</b></p> <p><b>1.37"width and 1.981b weight slim DC power supply</b></p>  <ul style="list-style-type: none"> <li>▪ 8 to 320V/80W</li> <li>▪ Selectable output range</li> <li>▪ Digital remote control</li> <li>▪ Universal Input voltage</li> </ul>	<p><b>AMS / AMT series</b></p> <p><b>High-speed and high voltage amplifier power supply</b></p>  <ul style="list-style-type: none"> <li>▪ High-speed response</li> <li>▪ Operation with desired waveform</li> <li>▪ For beam polarization, corona discharge, etc</li> <li>▪ <math>\pm 300V</math> to <math>\pm 20kV</math> / 100kHz</li> </ul>
<p><b>RK400 series</b></p> <p><b>Highest power and smallest size in its class!</b></p>  <ul style="list-style-type: none"> <li>▪ High power 400W in compact size 4.88" x 2.75"</li> <li>▪ Power factor correction 0.99</li> <li>▪ Worldwide universal input 85V to 264V</li> </ul>	<p><b>ES series</b></p> <p><b>Handy-type high voltage power supply</b></p>  <ul style="list-style-type: none"> <li>▪ Excellent stability as well as low ripple</li> <li>▪ Short circuit protection.</li> <li>▪ Convenient for experiments because of its small-size and lightness</li> <li>▪ 1kV to 5kV / 6W, 15W</li> </ul>

## 1. Product and specification

- Matsusada reserves the right to make any changes in the contents of catalogs or specifications at any time without advance notice. Due to compelling reasons such as unavailability of components used, products might be unavailable or unable to repair. Please contact the nearest sales office for the latest specification. • Specifications in this catalog is at the maximum rated output after warm-up unless otherwise specified. • The products specified in catalogs or specifications are designed for use by the person who has enough expertise or under the control of such person, and not for general consumers.

## 2. Warranty Policy

Matsusada Precision Inc. ("Matsusada") warrants that the products supplied by it will be free from defects in materials and workmanship for a period of twelve (12) months from the date of original shipment to buyer. This warranty shall not apply to any product which has been repaired, modified or worked on by persons unauthorized by Matsusada, used other than in accordance with the instruction manuals, used in inappropriate environment (with corrosive gas, high humidity, etc) or damaged by any event beyond Matsusada's control such as force majeure. Matsusada shall in no way be liable for any incidental, special or consequential damages relating to this warranty. Matsusada's sole liabilities and the buyer's sole remedies shall be limited, at Matsusada's discretion, to a repair or replacement of the products. The foregoing warranty is in lieu of all other warranties, express or implied, including those of merchantability or fitness for a particular purpose.

As the products are not designed and manufactured for applications which require extraordinary reliability or safety, or affecting people's life (nuclear energy, aerospace, socially fundamental facility, medical equipment, etc), this warranty shall not be applied for such applications. The specific design and manufacturing might be required for such applications. No modification or supplement of this warranty shall be binding unless in writing and signed by a duly authorized officer of Matsusada.

## 3. How to Order

- Orders may be placed directly with the factory or sales offices (see page 156) by e-mail, fax or mail. • Some models might be discontinued even found in this catalog. Please contact the nearest sales office for latest information when ordering. • Standard lead-time is 2 to 3weeks. Please contact for the exact lead time at the time of order. • We accept credit card order. (Orders in USA only)

## 4. Instruction manuals and Test data

- Each rack mount and bench top power supply have 1 instruction manual. Extra instruction manuals available with charge. • Schematics of products shall not be submitted to users. Test result or test data for the products shall be available upon request with charge.

## 5. Quotation

- Please contact nearest sales office for pricing and quotation.