

NEW

Compact / High power of 5.5kW

High power, Versatile Programmable DC power supply

REK series

6V to 650V

2.5A to 600A

1.6kW to 5.5kW



(except some models)



REK series

2U compact unit with
high power output 5.5kW
Programmable DC power supply
with multi-function and excellent usability

7kW, 10kW models are also available.



1.6kW to 2.5kW models



3.6kW to 5.5kW models

Featuring broad output range and low noise switching configuration REK series is an ideal power supply for a variety of applications. In addition to its ultra slim body, which would not select the installation place, the sophisticated front panel design with smooth dial and individual output meters for voltage and current shall promise comfortable and smooth operation.



Compact and high power

5.5kW



Ideal for research and development with **low noise switching method**.



PFC circuit and **universal input** would not select the place of operation.



Various operations by connecting multiple power supplies, such as **master/slave**, is possible.



REK adopt **large 4-digit monitor display** for both voltage and current, which contributes to precise monitoring with better recognition.



Operability and safety are improved with new features of **key-lock function** and **acceleration rotary encoder**, which accelerate the output ramp up with the speed of rotating the encoder.

Lineup

7kW,10kW models are also available.

Please contact our office near you.

Output Voltage (V)	Output Current (A)	Output Power (W)	MODEL	Ripple		
				(mVrms)	(mArms)*	
0 to 6	0 to 220	1300	REK6-220	10	320	CE
	0 to 310	1860	REK6-310	10	1500	
	0 to 530	3200	REK6-530	10	900	
0 to 8	0 to 600	4800	REK8-600	10	3000	
0 to 10	0 to 150	1500	REK10-150	10	300	CE
	0 to 240	2400	REK10-240	10	500	
	0 to 340	3400	REK10-340	10	900	
	0 to 510	5100	REK10-510	10	3000	
0 to 15	0 to 100	1500	REK15-100	10	150	CE
	0 to 160	2400	REK15-160	10	300	
	0 to 227	3400	REK15-227	10	500	
	0 to 340	5100	REK15-340	15	600	
0 to 20	0 to 80	1600	REK20-80	10	160	CE
	0 to 125	2500	REK20-125	12	250	
	0 to 170	3400	REK20-170	15	300	
	0 to 260	5200	REK20-260	15	400	
0 to 30	0 to 53	1600	REK30-53	20	100	CE
	0 to 84	2500	REK30-84	20	160	
	0 to 115	3450	REK30-115	20	200	
	0 to 180	5400	REK30-180	20	260	
0 to 35	0 to 45	1600	REK35-45	20	90	CE
	0 to 72	2500	REK35-72	20	150	
	0 to 100	3500	REK35-100	30	230	
	0 to 155	5400	REK35-155	30	280	
0 to 45	0 to 35	1600	REK45-35	20	70	CE
	0 to 55	2500	REK45-55	30	100	
	0 to 78	3500	REK45-78	30	130	
	0 to 120	5400	REK45-120	30	180	
0 to 60	0 to 26	1600	REK60-26	20	50	CE
	0 to 42	2500	REK60-42	18	80	
	0 to 60	3600	REK60-60	30	100	
	0 to 90	5400	REK60-90	30	135	
0 to 80	0 to 20	1600	REK80-20	20	40	CE
	0 to 31	2500	REK80-31	20	60	
	0 to 45	3600	REK80-45	30	80	
	0 to 68	5440	REK80-68	30	100	
0 to 100	0 to 16	1600	REK100-16	20	25	CE
	0 to 25	2500	REK100-25	25	50	
	0 to 36	3600	REK100-36	30	60	
	0 to 55	5500	REK100-55	30	80	
0 to 150	0 to 10	1500	REK150-10	30	20	CE
	0 to 16.6	2500	REK150-16.6	25	35	
	0 to 24	3600	REK150-24	30	40	
	0 to 36	5400	REK150-36	30	55	
0 to 200	0 to 8	1600	REK200-8	40	15	CE
	0 to 12.5	2500	REK200-12.5	40	25	
	0 to 18	3600	REK200-18	40	30	
	0 to 27	5400	REK200-27	40	40	
0 to 300	0 to 5.3	1600	REK300-5.3	50	10	CE
	0 to 8.3	2500	REK300-8.3	50	18	
	0 to 12	3600	REK300-12	50	20	
	0 to 18	5400	REK300-18	50	30	
0 to 500	0 to 3.2	1600	REK500-3.2	100	5	CE
	0 to 5	2500	REK500-5	100	12	
	0 to 7	3500	REK500-7	100	15	
	0 to 11	5500	REK500-11	100	20	
0 to 600	0 to 2.7	1600	REK600-2.7	150	5	CE
	0 to 4.1	2500	REK600-4.1	150	10	
	0 to 6	3600	REK600-6	150	15	
	0 to 9	5400	REK600-9	150	15	
0 to 650	0 to 2.5	1600	REK650-2.5	150	5	
	0 to 3.8	2500	REK650-3.8	150	10	
	0 to 5.5	3600	REK650-5.5	150	15	
	0 to 8.5	5500	REK650-8.5	150	15	

* At 10 to 100% of rated output voltage and rated output current.

CE Please inquire the situation of CE certification. It is under procedure.

A power supply with -LDc option, -LDe option and -LEt option doesn't have CE marking.(Please refer to page 5 for -LDc option and -LDe option, and page 10 for -LEt.)

Standard function

Sink Current / Sink Current Prevention Function

REK series features **function to sink current**, and enable to decrease the voltage quickly when turning off the output or when control the voltage down, which increase the safety of operation. In case that continuous aging test in short interval, quick voltage fall time increase the efficiency of process. On the contrary by using **sink current prevention** function, it is possible to prevent voltage drop on the load by decreasing the current flow from load to power supply when turning off the power supply or when decrease the output voltage.

<NOTE> It is not possible to stabilize the output by controlling back current. In case of load which has inverse voltage or over rated voltage, such as inductive load or regenerative motor, protect the power supply by adding dummy resistor or diode to prevent back current.

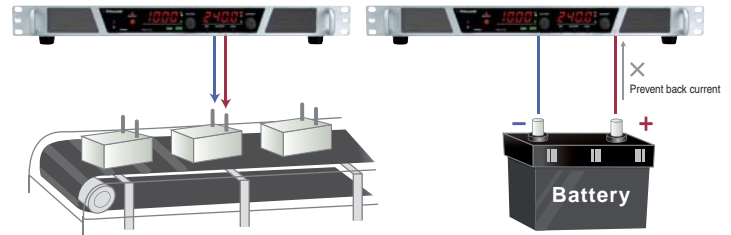

Multi Setting Function

Function to memorize **3 different voltage and current settings in addition to standard preset function**. No need to adjust the output when different setting, and convenient function for production inspection process or testing which require frequent data taking.

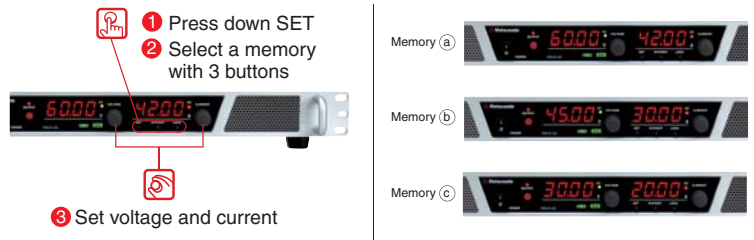

Two Mode Lock Function

Function to select two different lock modes for two different purposes. "Full Lock" locks all the functions on front panel, and "Normal Lock" locks all the functions except for ON/OFF switch. "Full Lock" mode shall be good in case mis-operation have to be completely avoided, and "Normal Lock" mode shall be good in case to avoid mis-operation but secure the way for emergency stop of power supply. You can select the best mode according to your level of "Security". (In both modes, emergency stop is possible with Power Switch.)

Full LOCK

Lock all the function other than reset lock mode. This mode is good for purpose to avoid mis-operation completely.

Normal LOCK

Lock voltage and current setting dial. This mode is good for purpose to avoid changing output setting by mistake or when easy emergency stop is required.

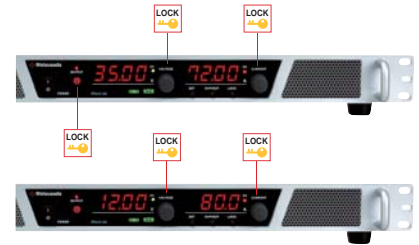

Delay Trigger Function

Function to output ON/OFF of total 32 units from one master unit.(when Master/Slave)* It is possible to delay the ON/OFF time, and simultaneous ON/OFF setting is possible as well. Ideal function for application which requires to turn on power one by one or time lag.

*Master/Slave function is available on the model without -LGob, -LUs1, -LEt and -LDc option. Also Master/Slave is not available when using -LDc function.

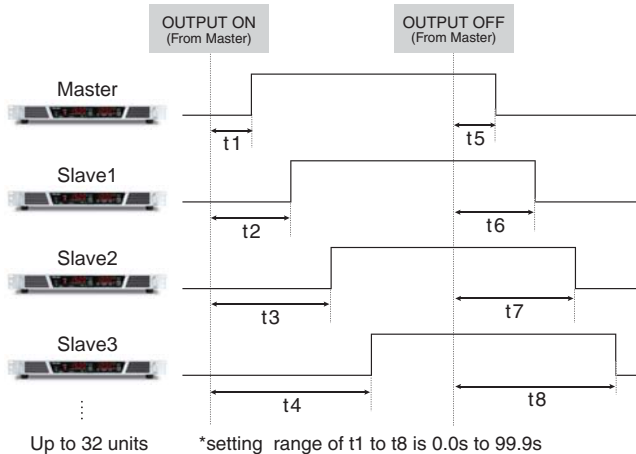

Dual Tracking, Multiple Outputs

Dual tracking control, which enables both positive and negative outputs simultaneously in master slave operation, is possible. Multi outputs and various versatile operations are also possible by combining above dual tracking control and slave local mode. Positive and negative output(+V, -V) of dual tracking control and set output voltage of slave local mode can be output simultaneously by turning on the master unit.

*Please refer to P.10 for detail connection.

Dual Tracking

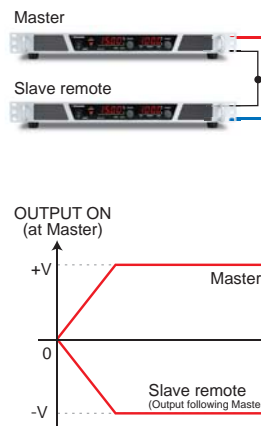

Multiple Outputs

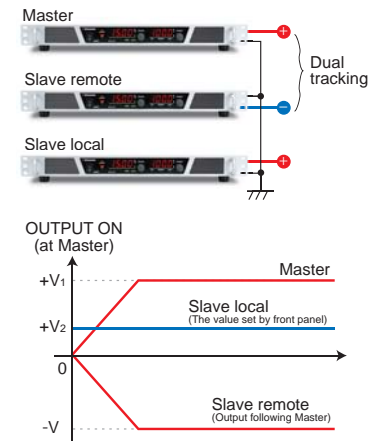

New useful functions

In addition to standard functions, these features offer many different usage and use in wide variety of applications.

Pulse / Ramp sequence, Master follow function(-LDc option)

above output control, between A to E is available.

A. Pulse Sequence

Using the stored voltage and current setting in each memory of a, b and c and multi set function, sequence operation is possible. The setting of repetition to say nothing of a continuous driving can be set. Various different operations, such as repetition of memory a and b or b ,c and off, are possible by setting the set time of memory a, b, c, and/or off to be 0.0. Thus, it makes this model suitable for evaluation test or other applications.

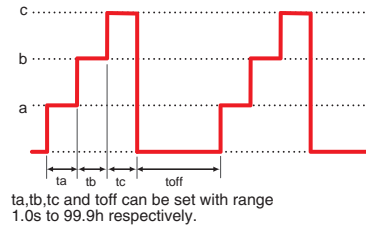

B. Ramp

This function controls the ramping up and down the voltage and current to the set value (or from set voltage and current value to 0V/0A). It is convenient to increase(decrease) the voltage and current value slowly.

*The Ramp sequence can be selected from [both set voltage and current], [only set voltage], and [only set current].

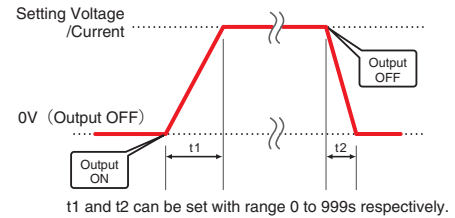

C. Combination of Pulse and Ramp Sequence

Features of pulse sequence operation and ramp sequence operation can be combined for more convenient operation. In addition, by adding multi set function, sequence operation can be operated using stored voltage and current settings in each memory. The setting of repetition to say nothing of a continuous driving can be set. For example it is possible to slowly ramp up and down the voltage and current to the three different settings, and so, it is useful on various scenes.

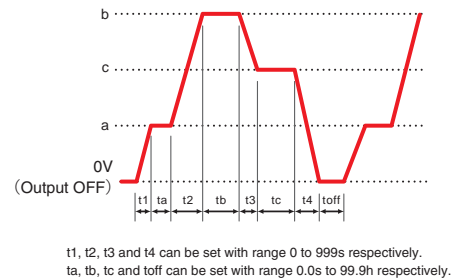

D. Delay trigger ramp

Combination of delay trigger and ramp function.
After turning Output on, It shall start increasing ramp voltage in several after brief space of time.

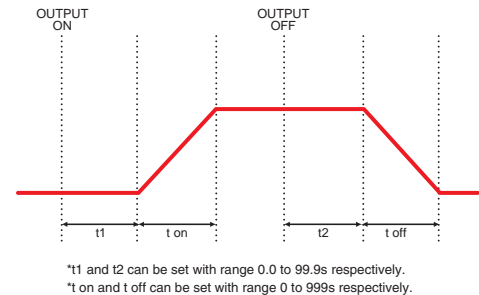

E. Master follow

When the pulse sequence operation and the ramp work master-slave, the output signal to the slave unit is transmitted. The slave unit can be output in an output status different from the master unit.

* Master follow function cannot be used with -LGob, -LUs1, and -LEt option.

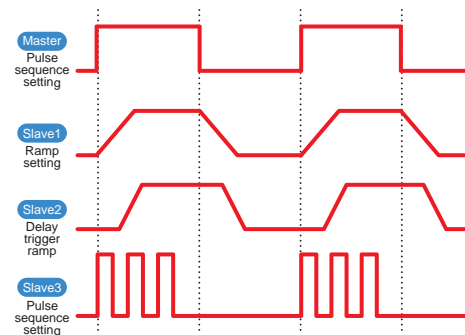

Pulse / Ramp sequence function(-LDe option)

above output control, between A to C is available.

Note The operation accuracy of the timer when sequencing is 0.5%. Be careful when you use it by the long-term running operation.

Functions

Sink Current / Sink Current Prevention Function

Front Panel



Rear Panel

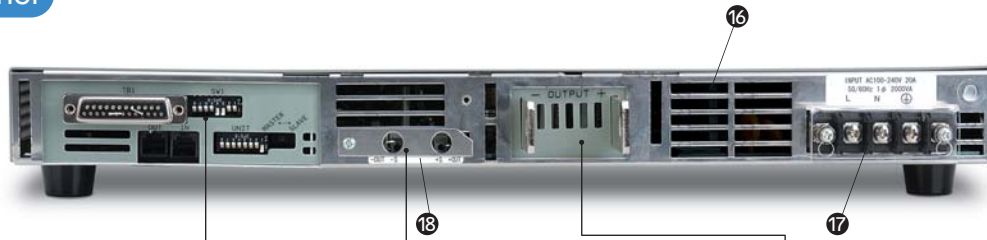

Function setting switch(SW1)	Remote sensing	Output terminal
<p>[Voltage Control]</p> <p>0V to 10V Local ↔ 0Ω to approx. 10kΩ</p> <p>[Current Control]</p> <p>0V to 10V Local ↔ 0Ω to approx. 10kΩ</p> <p>[Blackout Protection]</p> <p>OFF ↔ ON</p> <p>[Fail safe]</p> <p>OFF ↔ ON</p>	<p>Prevents voltage drop down ($V_o - V_L$) due to resistance (R) or deterioration of stability by contact resistance (Max compensation 0.5V)</p>	<p>Terminal board (more than 100V models)</p> <p>output cover</p> <p>Busbar (up to 80V models)</p>

- ① **Air intake**
- ② **OUTPUT**
Light on when output is ON.
- ③ **Output voltage, OVP setting display**
- ④ **Constant voltage mode**
- ⑤ **Output voltage, OVP setting dial**
- ⑥ **Output current, OCP setting display**
- ⑦ **Constant current mode**
- ⑧ **Output current, OCP setting dial**
- ⑨ **Power ON/OFF switch**
This has priority over all operations for safety reason.
- ⑩ **Output ON/OFF switch**
To be used to turn output on/off when local mode as well resetting protection functions.
- ⑪ **Keylock display**
Light on when key-lock condition.
- ⑫ **Remote programming display**
Light on when voltage/current remote control.
- ⑬ **Output preset switch**
- ⑭ **OVP/OCF setting switch**
- ⑮ **Keylock setting switch**
- ⑯ **Exhaust hole**
- ⑰ **AC input terminal (M4)**
- ⑱ **Not Sink Current switch**

**Input Voltage
Input Current**

	Input Voltage (50/60Hz)	Phase	Input Current* ¹	Input Current Protection	Model
1.6kW	100VAC to 240VAC	1Ø	23A @ 100V	Fuse 30A	Standard
2.5kW	200VAC to 240VAC	1Ø	16A @ 200V	Fuse 30A	Standard
	200VAC to 240VAC	3Ø	10A @ 200V	Fuse 30A	Option -L(3P)
3.6kW	200VAC to 240VAC	1Ø	26A @ 200V	Fuse 30A	Option -L(1P)
	200VAC to 240VAC	3Ø	16A @ 200V	Fuse 30A	Standard
5.5kW	380VAC to 415VAC	3Ø	8A @ 400V	Fuse 15A	Option -L(400V)
	200VAC to 240VAC	3Ø	24A @ 200V	Fuse 30A	Standard
	380VAC to 415VAC	3Ø	12A @ 400V	Fuse 15A	Option -L(400V)

Power factor : 0.99 typ.(1Ø) 0.95 typ.(3Ø)

*1: At maximum output power

*2: Rated input voltage range is between 100 to 240VAC(50/60Hz)while applying CE mark.

Output control

Local: Constant voltage: rotary encoder on front panel
Constant current: rotary encoder on front panel

Remote: Constant voltage: external control voltage 0Vdc to 10Vdc or external variable resistor 0Ω to approx. 10kΩ
Constant current: external control voltage 0Vdc to 10Vdc or external variable resistor 0Ω to approx. 10kΩ

Voltage regulation

Line: 0.01% of maximum output (for 100Vac to 250Vac±10% input change)

Load: 0.01%+2mV of maximum output (for 10% to 100% load change)

Current regulation

Line: 0.01% of maximum output (for 100Vac to 250Vac±10% input change)

Load: 0.02%+5mA of maximum output (for 10% to 100% load change)

Stability

0.05%/8Hr of maximum output voltage

Temperature coefficient

0.01% / °C of maximum output voltage

0.04% / °C of maximum output current

Output display

Output voltage: 4-digit meter (±0.5%FS±1digit at 23°C±5°C)

Output current: 4-digit meter (±0.5%FS±1digit at 23°C±5°C)

Monitor output

Output voltage monitor: 10V / maximum output voltage

Output current monitor: 10V / maximum output current

Protections

Over voltage protection (OVP) Output is cut off at a set value.

Over current protection(OCP) Output is cut off at a set value.

Setting range: 5% to 110% of rated output

Local setting: Rotary encoder on front panel

Reset: Manual recovery by OUTPUT switch or remote switch.

Over temperature protection (OTP)

Output is cut off when internal part is heated abnormally.

Reset (after the temperature has gone down to normal):

Manual recovery by OUTPUT switch or remote switch.

Input brownout(ACF)-Blackout protection

Output is cut off when input voltage decreased.

Reset (when normal voltage value or recovery from blackout):

Manual recovery by OUTPUT switch or remote switch

for blackout protection (re-output protection function).

Automatic recovery when blackout protection is canceled.

Sense reverse connection

Interlock

Other functions

Keylock to avoid misoperation.

Digital master slave operation. (up to 250V for series operation)

(Max 32 units for parallel or series connection.)

(Combination of parallel and series is not possible.)

Setting memory function

Quiet forced air cooling

Remote sensing

Remote switch ON/OFF (TTL or external relay)

Status signal output (CV, CC, FLT, OUTPUT)

Delay trigger function : ON delay and OFF delay can be set individually

(0.0 to 99.9 sec)

Multi set function : Voltage and current memory "a", "b" and "c" can be

set in addition to standard preset function.

Transient response time

Recovery time 1ms (for 70% ⇄ 100% load change)

Operation temperature

1.6kW model 0°C to +50°C (when input is 120VAC to 264VAC.)

0°C to +40°C (when input is 85VAC to 120VAC.)

When the input voltage is below 100VAC, the output power is to be derated at 1.2kW max.

2.5kW to 5.5kW model 0°C to +50°C

Storage temperature

-20°C to +70°C

Storage humidity

0% to 80% RH (no condensation)

Dielectric voltage

Between input power supply and output terminal : AC2000V 1 minute

Between input power supply and chassis : AC2000V 1 minute

Between output terminal and chassis : DC1000V 1 minute

Accessories

-Instruction manual (1)

-Output terminal cover (1)

-Remote connector cover (1)

-CO-M cable 2m (1) <when without option>

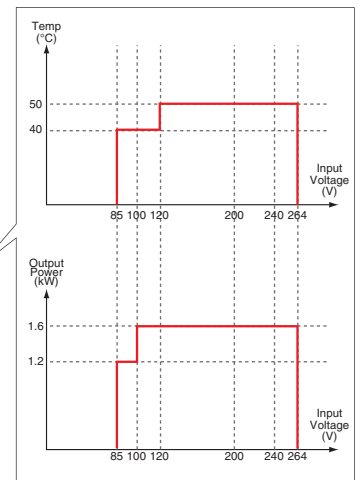

Connection and Remote control

Digital Interface

Able to one control master-slave operation in addition to digital control by USB / LAN(Ethernet) / RS-232C / RS-485 / GPIB

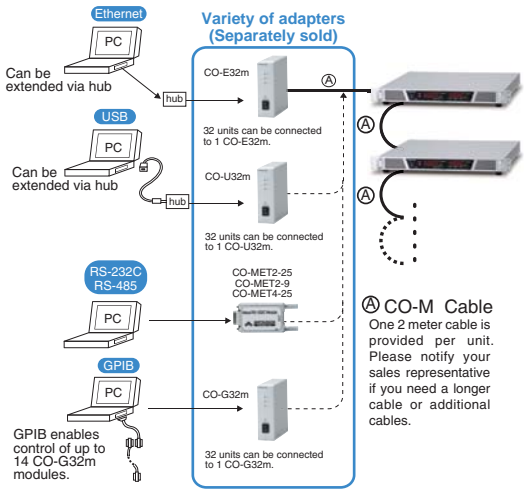

-L Gob option will be needed if it will be used under specific condition. Please see P.10 for detail.

Master / Slave Control

The Master / Slave control function allows you to control up to 32 units connected in parallel from a single unit.

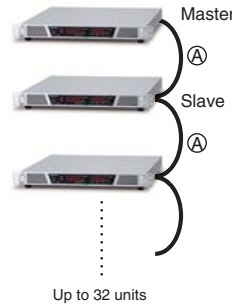

Master / Slave control is only possible with units with the same model number.

Delay trigger function at Master/Slave control can be set for each unit. Furthermore delay trigger function at Master/Slave control can cancel one control functions except for Output by switching Remote/Local, and can set voltage and current preset.

Remote Switch ON / OFF

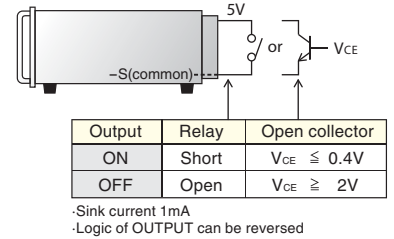

Remote Control

Remote/Local change

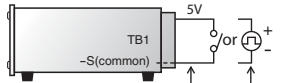

Mode	External relay	TTL
Remote	Short	Low
Local	Open	High

Each of voltage, current, OVP, OCP or all the modes can be switched by relay or TTL signal.

Output control



Vout · Iout	Control voltage	R *
0 to MAX	0 to 10Vdc input imp.500kΩ	0 to approx. 10kΩ

★Possible to change 10kΩ to 0Ω for fail safe



Vout · Iout	Control voltage
Max ×5 to 110%	0 to 10Vdc input imp.20kΩ

Output Monitor

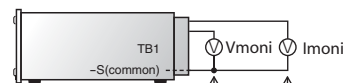

Output	0 to 10Vdc Output imp.1kΩ	0 to 10Vdc Output imp.1kΩ
0 to MAX		

Status Output



OUTPUT ON when OUTPUT
FLT ON when fault *
CV CC ON when each mode

*On when OVP, OCP, OTP, ACF, reverse connection of sensing or interlock(LD) status.

Common is floating in open collector output of common. With stand voltage 30Vdc, sink current 5mA or less.

Various Digital Control Functions

Control function	Output ON/OFF setting Status output (fault/output/OVP/OCP/OTP/ACF/reversible sense connection/interlock) Maximum 32 units digital control One control function for multiple units
Write function	Output voltage setting/Output current setting Percent mode(100.00%), *voltage current value mode(maximum rated voltage and current value)
	OVP setting/OCP setting Percent mode(100.0%), voltage current value mode(maximum over voltage/over current protection value)
Reading function	Output voltage reading/Output current reading Percent mode(100.00%), *voltage current value mode(maximum rated voltage and current value)
	Output voltage setting/Output current setting Percent mode(100.00%), *voltage current value mode(maximum rated voltage and current value)
	OVP setting/OCP setting Percent mode(100.0%), voltage current value mode(maximum over voltage/over current protection value)

* Minimum value of each model is same as minimum display of front panel meter.

Dimensions inch(mm)

There are exhaust holes on rear panel for forced air cooling.
 In case placed in a closed cabinet without extra room, apply additional forced cooling.

Busbar output type

1.6kW, 2.5kW Models Weight 8kg typ.

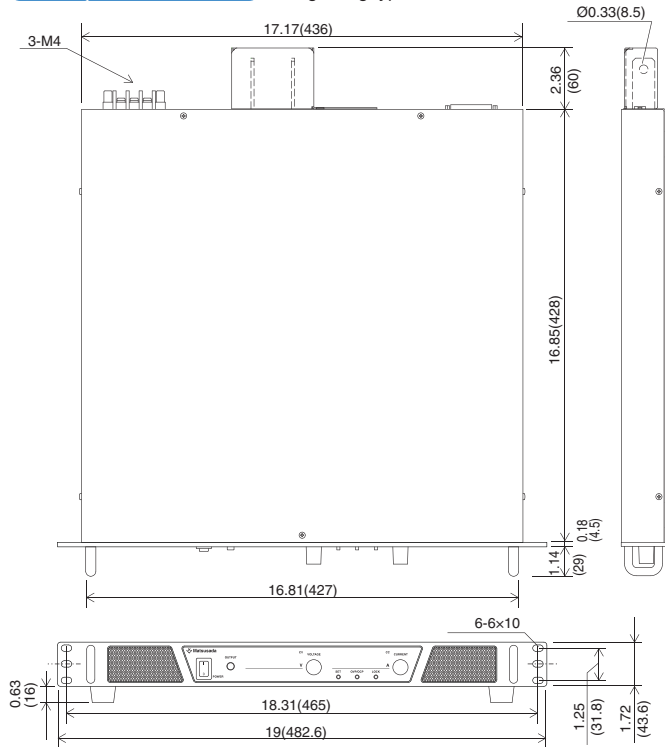

Terminal board output type

1.6kW, 2.5kW Models Weight 8kg typ.

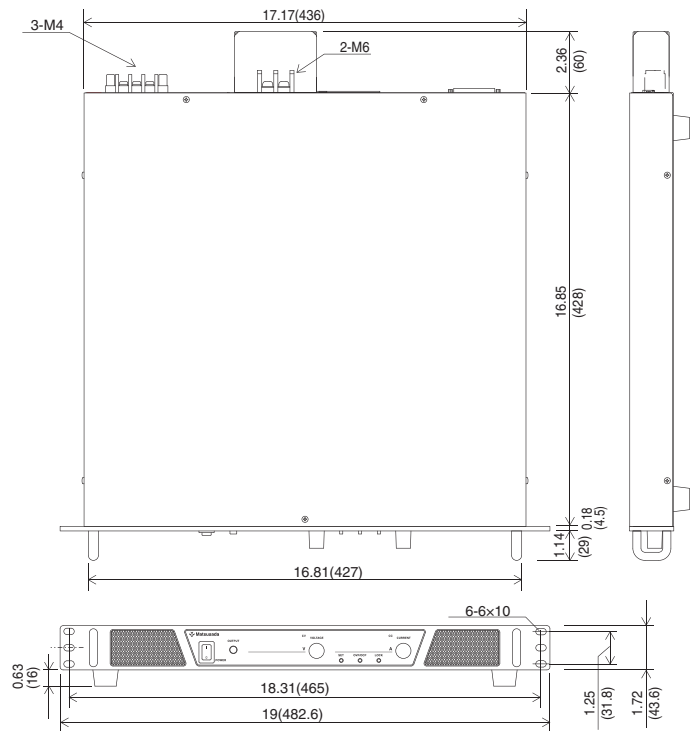

3.6kW, 5.5kW Models Weight 14kg typ.

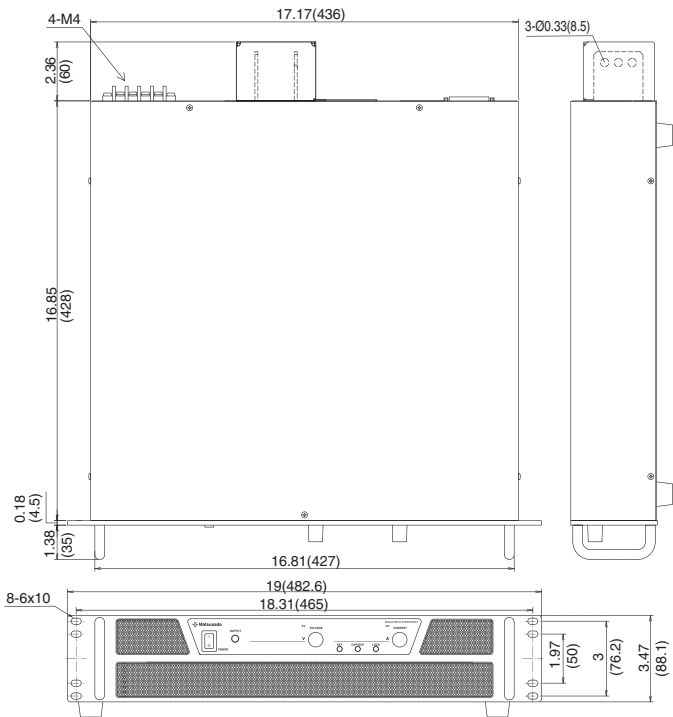

3.6kW, 5.5kW Models Weight 14kg typ.

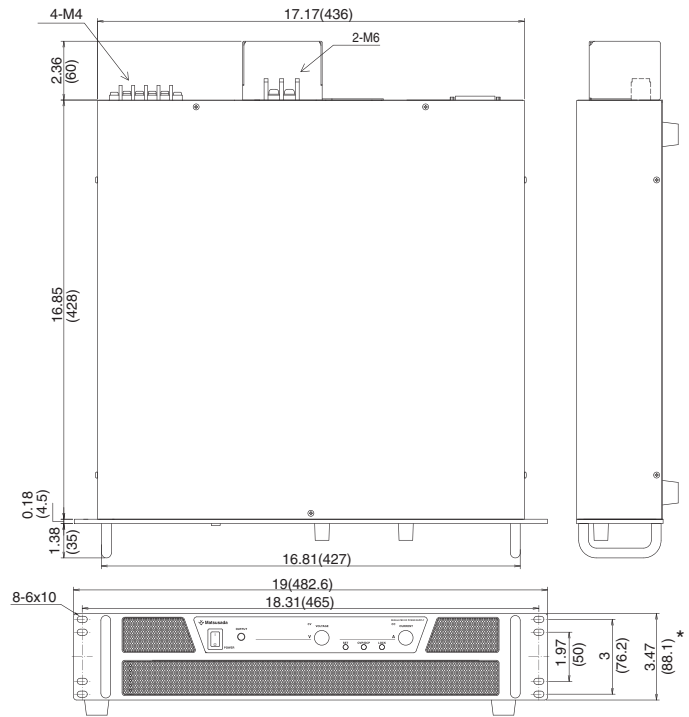

Operation example

REK power supply of same model number can be connected in series or parallel to increase output voltage or current.

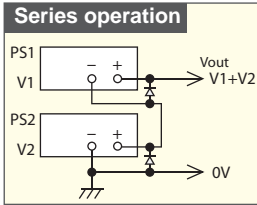

[caution]
Total output voltage is to be up to 250V. Therefore for models with output voltage of over 250V, series operation cannot be conducted. Output current is to be the smallest current of those. Additionally, the remote switch is connected to -output, so do not connect to the other remote switch simultaneously.

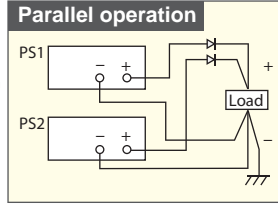

[caution]
Please keep all the settings of voltage the same. Output current will be the summation of each current. And, please keep OVP level of power supply maximum to prevent any damage.

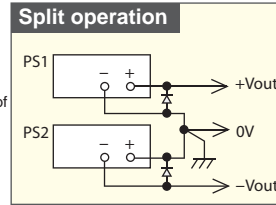

[caution]
Remote switch is connected to -output, so do not connect to the other remote switch simultaneously.

Options

-LGob : Optical Interface Board^{*1*2}

- LGob : Optical Interface Board + 2 meters long optical cable
- LGob(Fc5) : Optical Interface Board + 5 meters long optical cable
- LGob(Fc10) : Optical Interface Board + 10 meters long optical cable
- LGob(Fc20) : Optical Interface Board + 20 meters long optical cable
- LGob(Fc40) : Optical Interface Board + 40 meters long optical cable

It is isolated by optical communication. It makes it possible to prevent malfunction caused by transient phenomenon such as surge, lightning, induction, and external noise due to perfectly isolated by optical fiber.

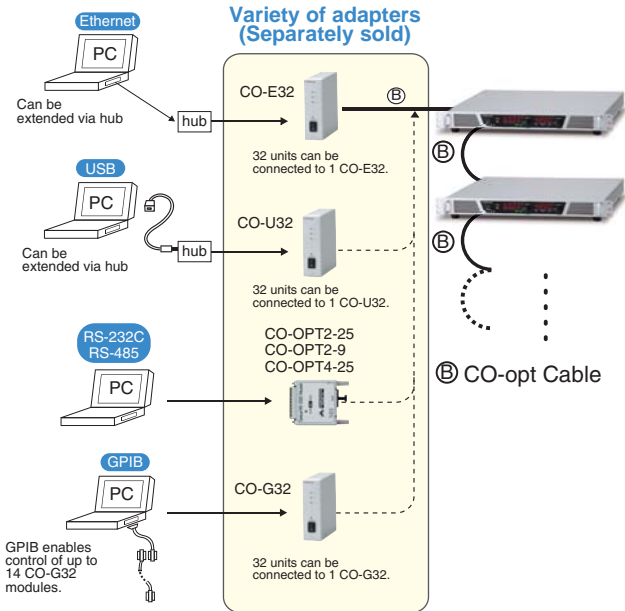

In case power supply will be use following condition, make sure this options selected.

- Noisy environment such as factories. (ex. usage of motor and coil around load or power supply)
- Usage on high voltage floating (more than 250V)
- In case the distance between power supply and controller (PC or PLC) is longer than 2-meter long.

-L(400V), -L(3P), -L(1P) Input Voltage, Phase

Please see page 7.

A power supply with this option doesn't have CE marking.

-LU1 : USB Interface Board^{*1*2}

Enable digital control via USB



When controlling several REK power supplies via USB, a USB hub will be required between the PC and REK power supplies.

-LEt : Ethernet Interface Board^{*1*2}

Enable digital control via Ethernet



Hub shall be required between REK and personal computer when control multiple REK via Ethernet.

A power supply with this option doesn't have CE marking.

-LDc : Pulse / Ramp sequence, Master follow function -LDe : Pulse / Ramp sequence function

Please see page 5.

-L(Mc0.5)^{*2}, -L(Mc0.15)^{*2} Communication cable extension

The length of CO-M cable will be 0.5-meter long 0.15-meter long.

Single phase AC input cable (3-pin type) separate

25A / 250V single phase open terminal

- Model** CABLE TYPE 5 : Standard 2.5m length
CABLE TYPE 5() : Extended length(1m increment)
<e.g.> 5m : CABLE TYPE 5(5)

*1 If you select this option, standard digital interface and master-slave function will not be equipped. Also, please see the CO series catalog for detail of function of digital interface function.

*2 These options cannot be selected together. Only one of each can be selected.

When ordering, suffix the above option number to the model number.

- <e.g.> REK30-84-L(Mc0.5)(3P)
REK100-36-LDcGob(Fc20)(1P)
REK500-11-LDeUs1(400V)
(Alphabetical order)

TECHNICAL NOTE

Connection · Operation

■ Connection of load

- Please use a short lead wire that is sufficiently thick for the connection.
- Please use PVC electric cable (105°C) that can fully tolerate the voltage used. It is necessary to consider current capacity, length limit of output wire by sensing (0.5V/lead) and so on for wiring with load. Please refer to the following diagram to determine the thickness of cable.

AWG	mm ²	Max current(A)
18	1.1	2
16	1.3	7
14	2.1	11
12	3.3	18
10	5.3	23
8	8.4	39
6	13	67
4	21	106
2	33	170
1	42	209
1/0	53	270
2/0	67	330
3/0	85	350

Use several cables or copper bar for model over 350A.

■ Parallel connection of load

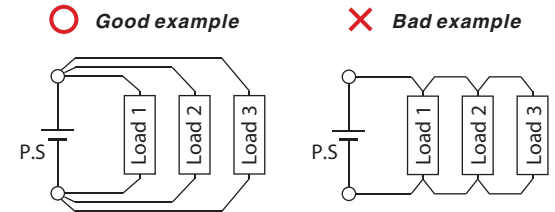

■ Connection of load

Please insert a diode of which rating is bigger than output voltage and current of power supply to protect the power supply from kick back of load.

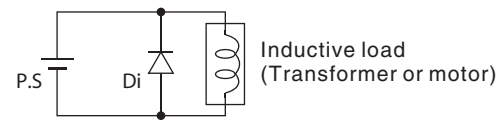

Definition of specifications

Specifications in this catalog, except otherwise specified, refer to values when maximum rating output (full scale★) after 2-hour warm up.

Applicable scope of specifications

"F.S × catalog value(★)" is applied for ripple, stability, regulations and temperature coefficient, and "value if F.S × ±1%(★)" is applied for high-voltage output linearity, monitor linearity and display linearity, both in the range of 10% to 100% of maximum rating output.

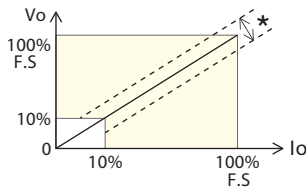

Ripple

Indication is in rms that includes high-frequency noise.

Preset

Preset value does not show the actual output status accurately. If you need an accurate setting, conduct actual output without load and set a voltage. Also for setting current, conduct output after shorting the output terminal and gradually raise current before setting at a desired value.

When selecting DC power supply

▶ Important Notice

Products on this catalog have been manufactured with consideration of safety as DC power supply, however please follow instruction manual for operation and make sure to ground the ground terminal for your safety.

Products on this catalog have been manufactured on the precondition that they are used in ground electric potential or within the range of the above series operation. Please contact our sales staff when using the product for floating of high electric potential, etc.

Products on this catalog are manufactured with consideration for protection against load discharge. However for specific experiment or continuous discharge such as sputtering, product may need discharge resistance between power supply and load or could not be used at all. Please consult with our sales staff in advance.

We recommend that you contact our sales staff with your requirement before choosing a product so that you can get the best product and the safety as high-voltage equipment is assured.

